

MVT 665/675

TURBO

- Max. lift height : 6.00 m
- Capacity : 6500/7500 kg
- Maximum forward reach : 3.73 m
- Hydrostatic transmission



MANISCOPIC

MANITOU



Reach at maximum height : 1.40 m

MVT 665 T/675 T



Lift capacity.....6500 kg7500 kg
at 600 mm from forks heels.



Lift height :5.80 m.....5.80 m



Tyres
MVT 66518 - 22.5 T35 16 PR TL
MVT 67518 - 22.5 XF



Forks (mm)
Length1200
Width x thickness200 X 60
Maximum distance between forks1430
Carriage rotation.....MVT 665 T.....135°
MVT 675 T.....115°



Multidisc brakes - hydraulically assisted on both axles



PERKINS Engine
Type.....1004.4 Turbo
Capacity4 cyl. - 3990 cm³
Power (DIN 70-020)106 HP/78 kw
Rated speed :2300 rpm
Direct Injection
Water Cooling



Hydrostatic transmission
Electro-hydraulic reversing shift
Hydraulic variable displacement pump and motor
2 speeds forward and reverse
Maximum travel speed.....25 km/h



Hydraulics
Gear pump :275 bars/140 l/mn
Flow divider with loadsensing device driving



Capacities
Cooling system.....16 l.
Engine oil :8.1 l.
Hydraulic oil110 l.
Fuel tank100 l.



Weight unladen (with forks)11400 kg .12100 Kg
Overall width.....2.44 m2.44 m
Overall height.....2.51 m2.51 m
Turning radius (outside wheels)3.57 m3.57 m
Overall length.....4.67 m4.67 m
Ground clearance0.49 m0.49 m
Drawbar pull10100 daN 10100 daN

MVT 665 T **MVT675 T**

MVT 665 T **MVT675 T**

MVT 665 T **MVT 675 T**

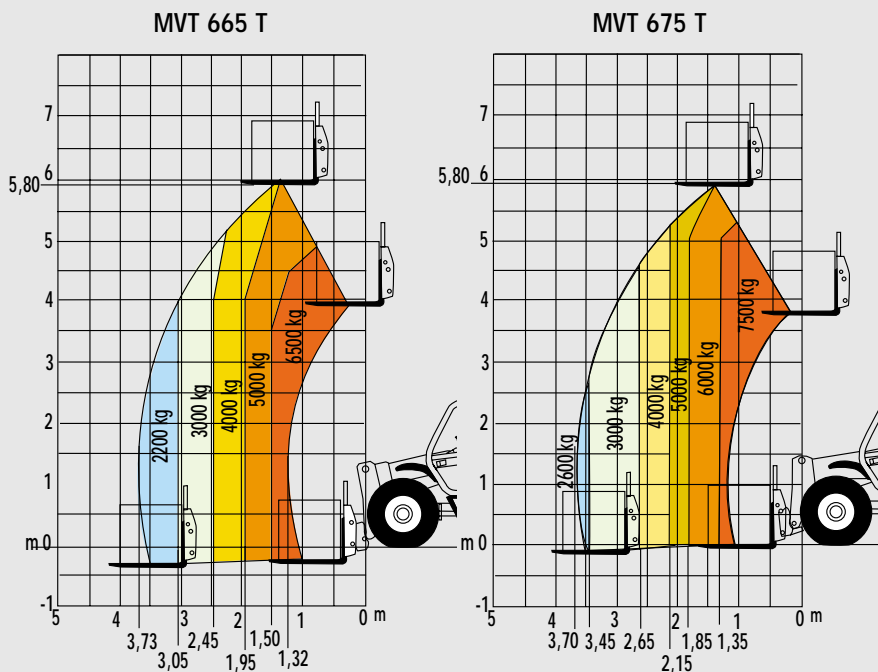

Under EN 1459 annexe B

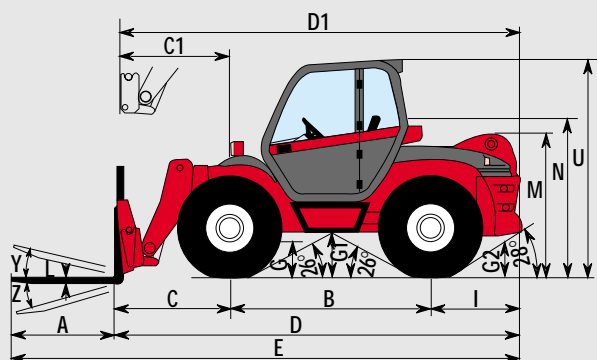

A	1200
B	2500
C	1010
C1	870
D	4670
D1	4530
E	5870
F	1990
G	400
G1	490
G2	400
I	1160
J	865
K	1430
L	60
M	1850
N	1890
O	200
R	3340
S	7025
T	3950
U	2510
V	4450
V1	950
V2	3565
W	2440
Y	11°
Z	124°*

mm
*MVT 675 T : 104°

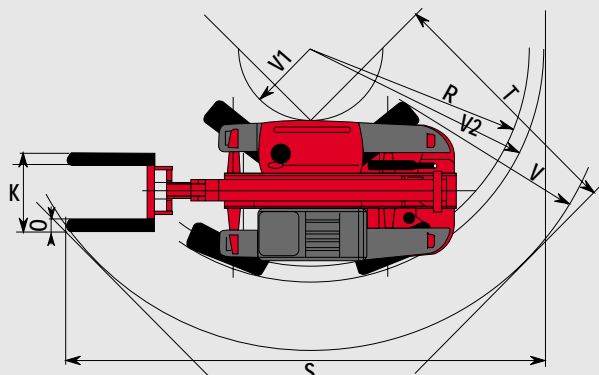
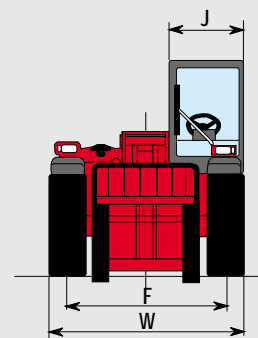

This publication in no way constitutes an offer and the company reserves the right to alter specification without prior notice.
The MANITOU models presented in this brochure can be supplied complete with optional equipment attachments



MANITOU B.F. S.A.
B.P. 249 - 44158 ANCENIS CEDEX - FRANCE
TEL : 33 2 40 09 10 11
EXPORT DEPARTMENT FAX : 33 2 40 09 10 97
www.manitou.com





